

**Soundweb™ 9088
Installation Guide**

Regulatory Information

v1.2 JK 4th June 1998

An example of this equipment has been tested and found to comply with the following European and international Standards for Electromagnetic Compatibility and Electrical Safety:

Radiated Emissions (EU):	EN55013	(1990) Associated Equipment
Immunity (EU):	EN50082/1	(1992) RF Immunity, Fast Transients ESD
Mains Disturbance (EU):	EN61000/3/2	(1995)
Electrical Safety (EU):	EN60065	(1993)
Radiated Emissions (USA):	FCC part 15 Class B	
Electrical safety (USA):	UL813	



Important user information

Do not remove covers. No user serviceable parts inside, refer servicing to qualified service personnel. For continued compliance with international EMC regulations, it is important that all cables be screened, and connected as follows: Audio cable screens to their 9088 connector ground. Control cable screens to the ground screws adjacent to the connector. Network cables should be of type CAT.5, fitted with a clip-on ferrite sleeve (STEWART TYPE 28A2029-0A0) near the network socket end. This equipment must be earthed. It should not be necessary to remove any protective earth or signal cable shield connections to prevent ground loops. Any such disconnections are outside the recommended practice of BSS Audio, and will render the EMC or safety certificate void.

Mechanical Installation

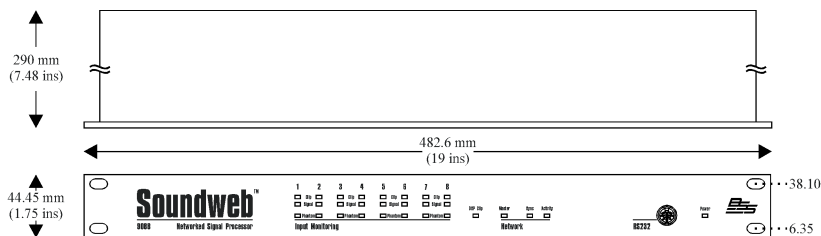

Note: All dimensions in mm.

If the unit is likely to undergo extreme vibration through extensive road trucking and touring, the unit must be supported at the rear and/or sides to lessen the stress on the front mounting flange. The necessary support can generally be bought ready-built as a rack tray, or the 9088 unit can be mounted between other units. Damage caused by insufficient support is not covered by the warranty. To prevent cosmetic damage to the front panel finish, use protective plastic cups under the rack mounting bolts.

Front panel LED functions

Input monitoring

Each channel has 3 LED indicators showing:

Clip

Illuminated - Excessive signal level, close to clip.

Signal

Illuminated - A signal is present on this channel input.

Phantom

Illuminated - Phantom power is active for this mic channel.

ALL flashing - Unit selected in Soundweb designer/Network view.

DSP Clip

Illuminated - Indicates that the signal is clipping internally.

Network

Master

Flashing - The network is initialising. If it continues to flash for more than a few seconds, there is a cabling fault - either a double ring error or a problem with one of the cable connectors.

Steady - This unit has become the clock master for the network.

Off - This unit is slaving to the master's clock.

Sync

Steady - This indicates the presence of one or more valid network connections.

Flashing - There is a problem with the incoming network signal - possibly the maximum cable length has been exceeded.

Activity

Flashing - This LED indicates data transfer. The flashing is not regular, but dependant on the rate of transfer.

Power

Steady - This indicates that the power supply is functioning.

Front panel details

RS232

Used to connect one of the 9088 units in the network to a controller PC (cable supplied with unit), which can then communicate with any device on the network. The pin out is:

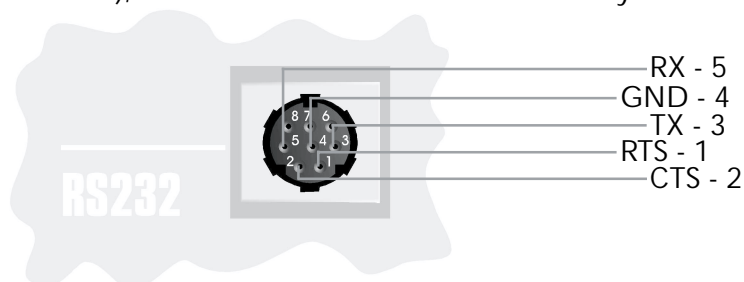

Audio & Control cable wiring details

All audio and control connections to the 9088 are via Klippon pluggable terminal block connectors (also known as BL, Phoenix or Combicon). 6-way female Klippon connectors are supplied for making these connections.

Audio Input and Output wiring convention

Soundweb products provide cable shielding 'back from the destination' to eliminate ground loop problems. This means that the shield (S) connection on an input is grounded, whereas the shield connection on an output is floating (although connected via an internal network to ground for EMC compliance).

Balanced wiring - The convention for balanced wiring (2-core plus shield) is:

Balanced connection 9088 connection

Pin 3: Cold '-'
Pin 2: Hot '+'
Pin 1: Shield

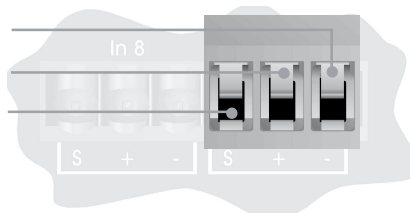

Unbalanced wiring - The convention for unbalanced wiring to the inputs (1-core plus shield) is:

Unbalanced connection 9088 connection

Pin 1: Shield
Pin 2: Hot '+'
Pin 3: Link to Pin 1
(Optional for 9088 inputs)

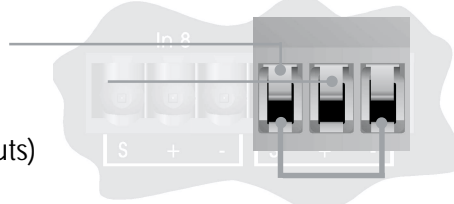

Rear panel details

Mains inlet

IEC power connector for removable mains supply.

Fuse holder

Mains fuse - requires a 20mm T1A type fuse.

Network In/Out

Network In - connects to the *Network Out* socket on another unit. Connecting multiple units is done in the same way - *In* to *Out*. This allows audio channels to be passed 'downstream' from the Net Out socket on one device to the Net In socket on the next device. The Soundweb system automatically completes this 'daisy chain' of device connections to form a loop (using a back-channel), as shown by the dotted line in the diagram below. This shows that audio channels may be routed back from the terminal device (the one without a connection on its *Net Out* socket) to the first device (the one without a connection on its *Net In* socket). There must be no physical cable connection between these two end devices however.

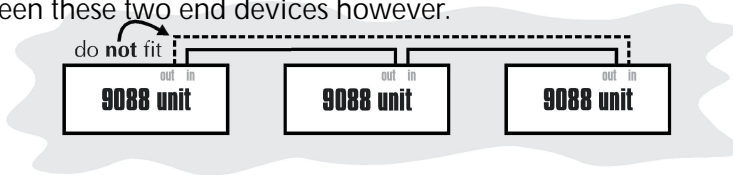

The connecting cable is CAT. 5 network cable, terminated with RJ45 connectors, with all 8 cores wired straight through.

Note that the twisted pairs in any CAT.5 network cable must be wired to the following pin pairs at each terminal:

- 1 (White-Orange) with 2 (Orange) 3 (White-Green) with 6 (Green)
- 4 (Blue) with 5 (White-Blue) 7 (White-Brown) with 8 (Brown)

Aux RS232

This is for connection to a PC, modem or AMX panel (a control PC may be connected here, or via the front panel RS232 port).

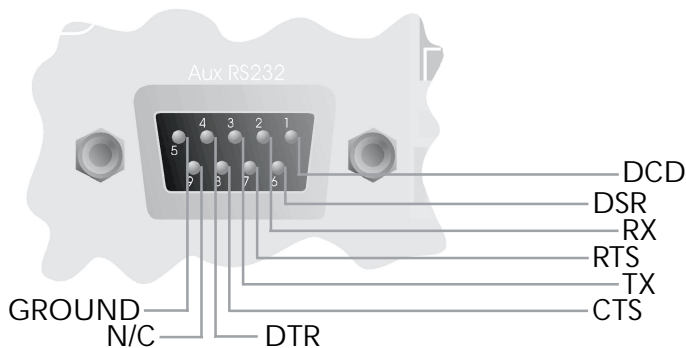

Control Inputs

Used to connect switches or potentiometers to the 9088. These eight inputs are internally 'pulled up' to +5V DC via a 4.7kOhm resistor, so no external voltage source is needed. Four common (ground) connections are provided (all connected together internally). A 47kOhm log potentiometer connected between one input and common will allow parameters to be controlled linearly. Alternatively, a switch may be connected between an input and common, or a multiway switch may be connected to several inputs with the wiper connected to common.

Logic Outputs

Used to connect the 9088 to 'tally' indicator LEDs or relays. There are eight standard logic outputs which produce 0V or +5V DC via an internal 440 Ohm resistor. Two common (ground) connections are provided (connected together internally). A LED connected between one output (Anode, A) and common (Cathode, K) will illuminate when the logic output is activated, without requiring any external current limiting resistor. A high sensitivity relay (such as a reed relay) may be driven by connecting four outputs in parallel. This arrangement will develop 4V across a 500 Ohm coil, providing that all four outputs are made logic 1 simultaneously.

Opto output

In addition to the eight standard logic outputs, there is an isolated output, which fails safe (open circuit) if the 9088 becomes faulty. This is effectively the collector-emitter of a transistor (which may be thought of as a switch) in series with a 220 Ohm protection resistor. In conjunction with an external DC power source (max 80V), this may be used to drive various loads such as relays.

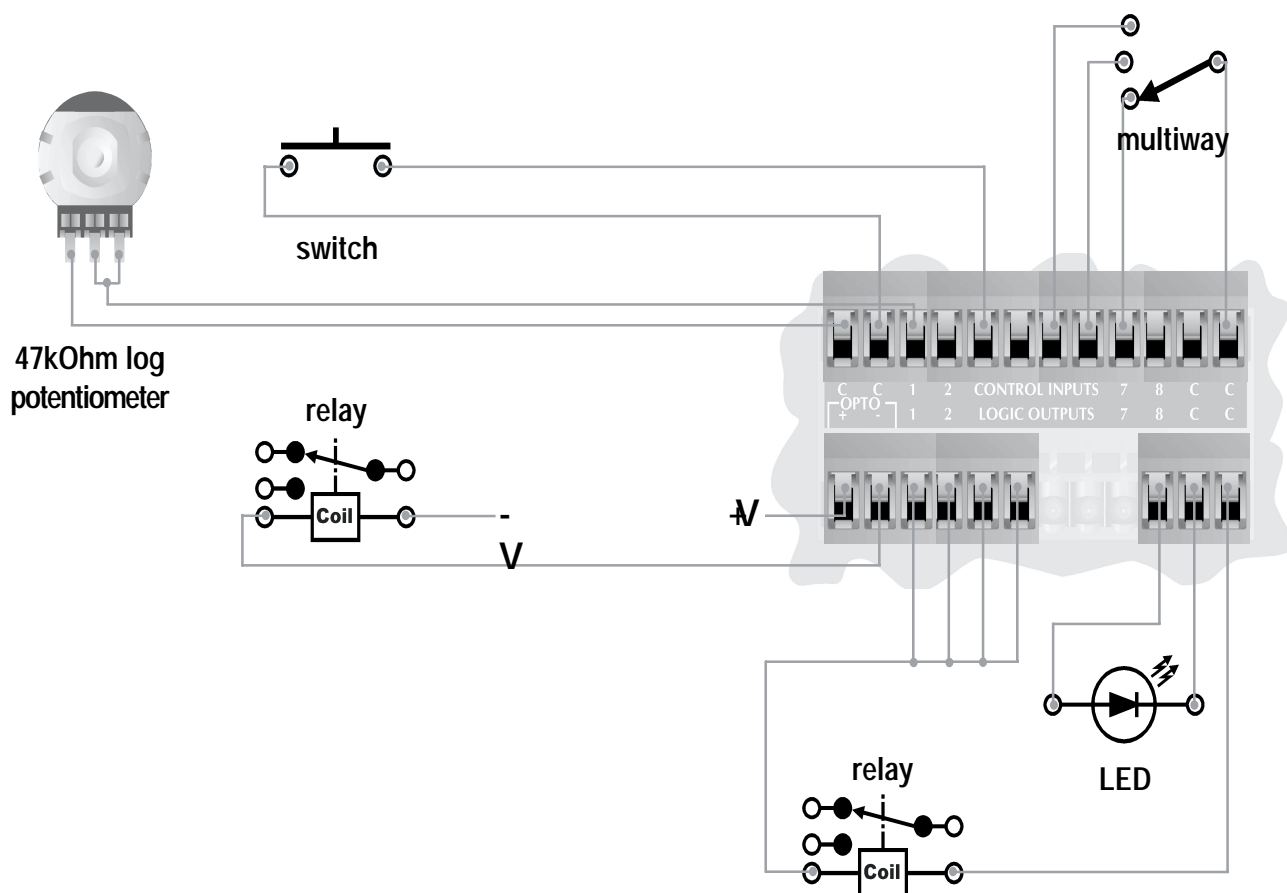

Technical specifications

General

Frequency response (+-0.5dB)	15Hz to 20KHz
THD	<0.01% (20Hz to 0KHz, +10dBu output)
Dynamic range	100dB typ. (22Hz to 22KHz unweighted) 103dB typ. (A-weighted)
Maximum output level	+20dBu
Inter-channel Crosstalk	<-75dB
Maximum network cable length	300m/1000ft
Power consumption	<35VA
Mains Volts	85-270V 50/60Hz

Line input card

Input Impedance	10kOhms
Maximum input level	+20dBu (+8dBu with 12dB gain)
Gain range	0 or 12dB

Universal microphone/Line input card

Input impedance	3.5kOhms
Maximum input level	+20dBu (with 0dB gain)
Gain range	0 to 70dB
CMRR	>75dB at 1KHz
Equivalent Input Noise (EIN)	<-128dBu typ with 150 Ohms source
Phantom power	48V nominal

Control ports

Logic output voltage	0 or +5V unloaded
Logic output impedance	440 Ohm
Opto output series impedance	220 Ohms (isolated)
Control input voltage	0 to 4.5v
Control input impedance	4.7kOhms to +5V
Opto Output current	14mA max
Opto output withstanding voltage (off)	80V max.